

RATTAN SOLAR TABLE LAMP

Assembly Instructions - Please keep for future reference

PD484

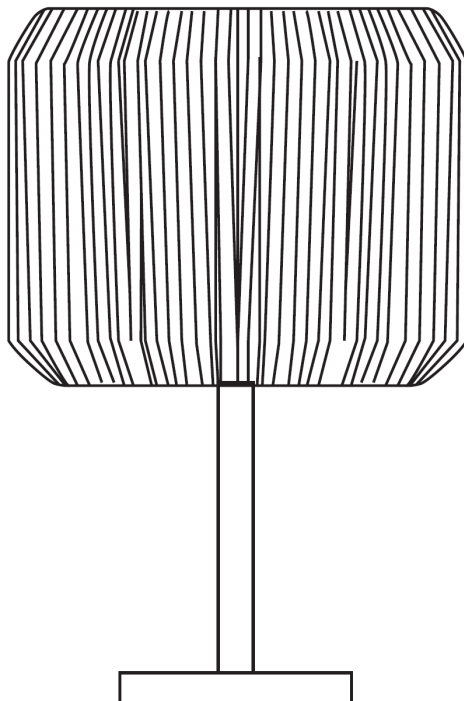

Important – Please read these instructions fully before starting assembly

Safety Information

IMPORTANT - This product has been designed for non-professional, domestic use only.

IMPORTANT - Dispose of all packaging correctly and responsibly and in accordance with all local laws and regulations. Never leave packaging components within reach of children as they can be a source of danger.

IMPORTANT - Carefully unpack and examine the product for any damage. If you think there is a defect, **do not** use the product

IMPORTANT - This is a class 3 product low voltage product, battery powered and not request power supply connection.

WARNING - Do not modify or alter any product before or after installation. This may render the product unsafe.

WARNING - This product is not intended for use by persons (including children) with reduced physical, sensory and mental capabilities, or lack of experience and knowledge, unless they have been given supervision or instruction concerning use of the product by persons responsible for their safety.

WARNING - Children should be supervised to ensure that they do not play with the product.

BATTERY SAFETY INFORMATION

- Do not dismantle, open or shred the battery.
- Do not expose the battery to heat or fire.
- Avoid storage in direct sunlight.
- Do not short-circuit the battery.
- Do not subject the battery to mechanical shock.
- Keep the battery out of the reach of children.
- Keep the battery clean and dry.
- Do not leave a battery on prolonged charge when not in use.

BATTERY CAUTION

The lithium rechargeable battery used in this device may present a risk of fire or chemical burn if mistreated. Do not Disassemble, short circuit, crush, expose to heat above 60°C or incinerate.



Installation

Dia.1.

1. Screw the pole to the base.
2. Remove the solar panel from the shade and attach the plastic lamp holder cover as illustrated.
3. Re-attach the solar panel with plastic cover to the shade.
4. Screw the shade to the pole
5. Placer the fitting on the required position turn the switch bottom from the solar panel on and test the fitting.

The LED light only can operate under a dark atmosphere.

Battery Replacement (If required).

Dia. 2.

1. Using a screw driver (not supplied), un-screw the side screws to separate solar panel box from the plastic round support.
2. Using a screw driver (not supplied), un-screw the screws from the solar panel box.
3. Open the box and remove the old battery.
4. Insert new Lithium-Ion battery and closed the box.
5. Re-screw all the solar panel box screws
6. Attach solar panel box to the plastic round support screwing the side screws.

This product is suitable to use Lithium-Ion battery cell or Li-Ion, abbreviated LIB **only**, any other batteries type are not accepted.

Maintenance

Cleaning

- Use a clean dry soft or slightly damp cloth.
- Do not use abrasive cloths or polishes as this may cause damage to the product.



Dia.1

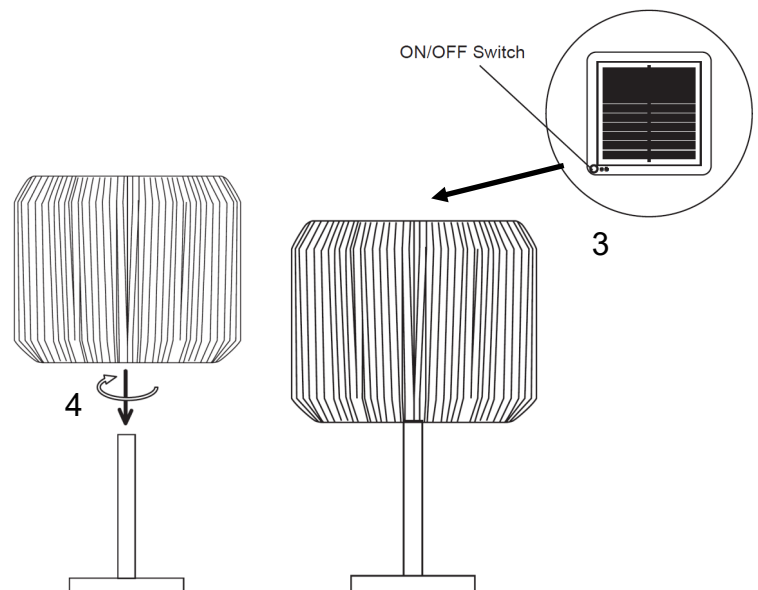
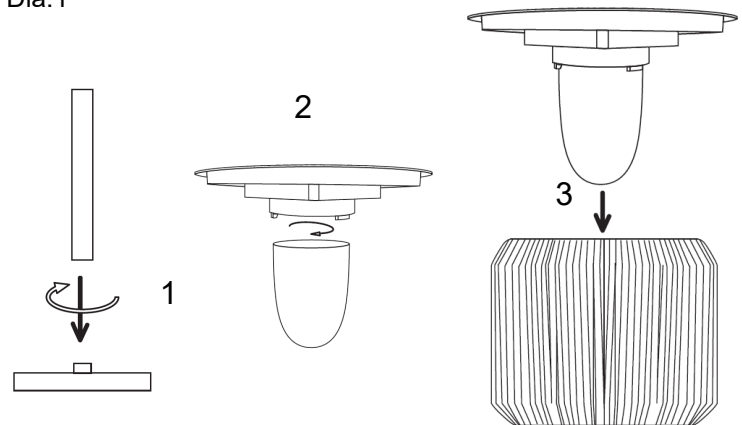

Dia.2

